

INSTALLATION GUIDE

NON-PRE HUNG

STORM DOORS



100



1085S



1202PSS

Tools & Materials You Will Need

- | | |
|--------------------------|---------------------------------------|
| • Measuring tape | • Level and a square |
| • Hammer and soft mallet | • Phillips and flathead screwdrivers |
| • Pliers | • Drill Bits (5/16") & (3/32") |
| • Power Drill | • Two saw horses |
| • Utility Knife | • Pencil |
| • Hacksaw | • Caulking gun with caulking—optional |

Installation Screw Pack:

- | | | | |
|--------------------------------|-------------------------------------------------------------------------------------|------------------------------|---------------------------------------------------------------------------------------|
| (20) Painted #10 1 1/4" screws |  | (2) Painted #8 3/8" screws |  |
| | | (8) 1/2" Self Tapping screws |  |



1202PSS

Your door package should include the following items:

- Door frame with glass and screen inserts
- One full set of Z bar including one hinge rail, one latch rail, and one drip cap
- One door expander (located on the bottom of the door)
- One package of (20) installation screws painted to match door color. (2) screws for expander, (8) 1/2" self tapping screws for hinges, closure kit, and touch up paint bottle
- Plastic retaining clips & screws to hold glass and screen inserts (installed on door).

Note: Self Storing models do not require polycarbonate clips.

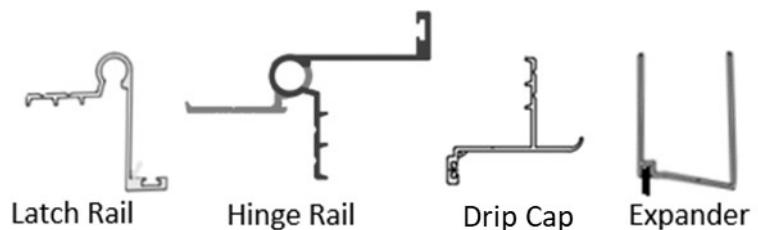

Latch Rail

Hinge Rail

Drip Cap

Expander

FIGURE 1
Door Hinging - Outside View

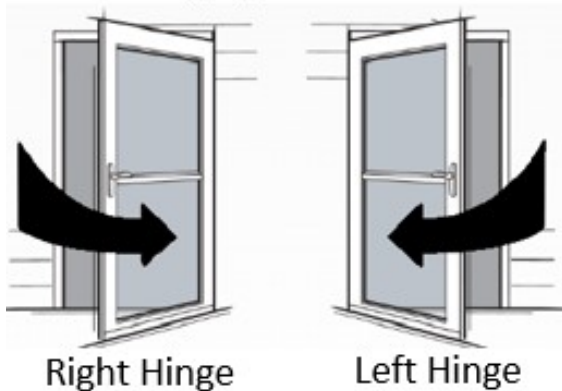

FIGURE 2

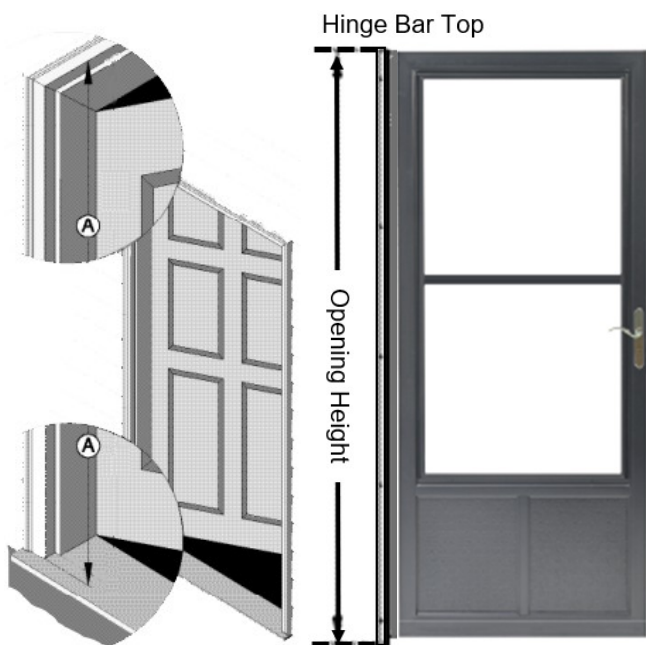
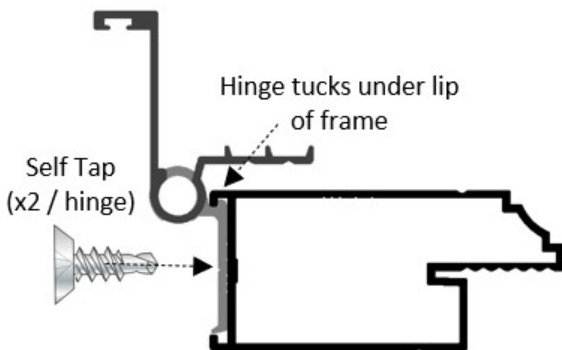

FIGURE 3



1. **UNPACKAGING:** Remove door from packaging and ensure all components are present. To lighten the door for easier installation, remove the glass & screen inserts. Be careful not to let the inserts drop out. Pull the expander from bottom of door. Note: Self-storing styles do not require removing glass and screen, but removing them will make the door easier to install. Re-install glass and screen after unit is installed.
2. **DOOR SWING:** Determine the swing of your door. See image above (Figure 1) for right hinge vs left hinge. Lay the door frame on a set of saw horses with the outside of the door facing up so that you are able to attach the hinge rail.
3. **MEASURING FOR HINGE RAIL:** To attach the hinge rail you must measure the overall inside opening where you are installing the storm door. To get this, you will need to get the measurement in (Figure 2) spot A. With a tape measure start from the top of the door sill / (threshold) and come up to the bottom side of the brickmold. Once you have your measurement, subtract a 1/8" off of it to allow clearance for the storm door header rail. This will be the length you want to cut the hinge rail to. So: $(A) - 1/8" = \text{Hinge Rail Length}$
4. **CUTTING HINGE RAIL:** You are better to cut the end of the rail that is closer to your door sill / (threshold). With your tape measure and pencil mark where you are going to cut the hinge rail. Using a fine tooth hack saw make your cut on the hinge rail / (threshold). For a nicer look make your cut the same angle as the slope of the door sill / (threshold).
5. **ATTACHING HINGE RAIL:** With the hinge rail cut, lay it along side the hinge side of your door frame as seen in (Figure 3). You will want to make sure the top end of the hinge rail is sitting 1/8" above the top of your door frame. This is so that there is a sufficient gap / reveal between your door and the header rail. Ensure all four of the hinges are tucked in the hinge side of the door. You will see that the hinge should tuck under the lip of the door frame in order to provide more load bearing strength.

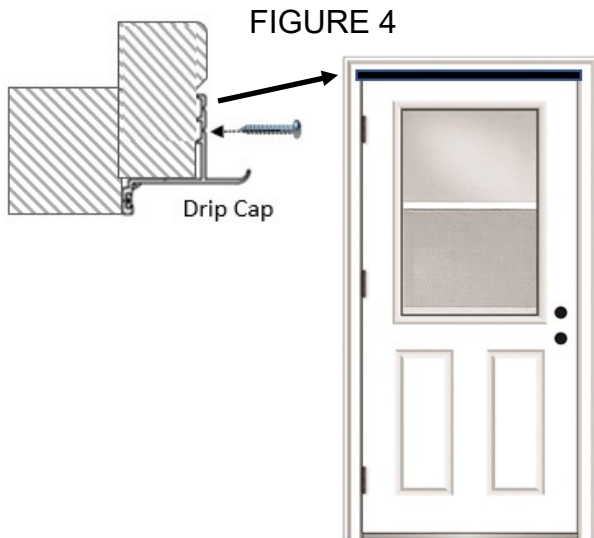

FIGURE 4

Drip Cap

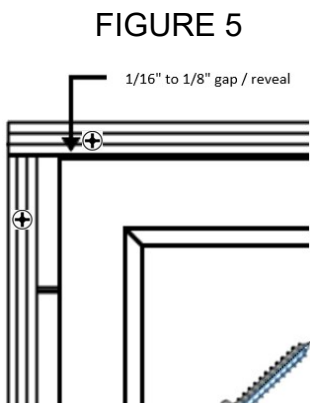

FIGURE 5

1/16" to 1/8" gap / reveal

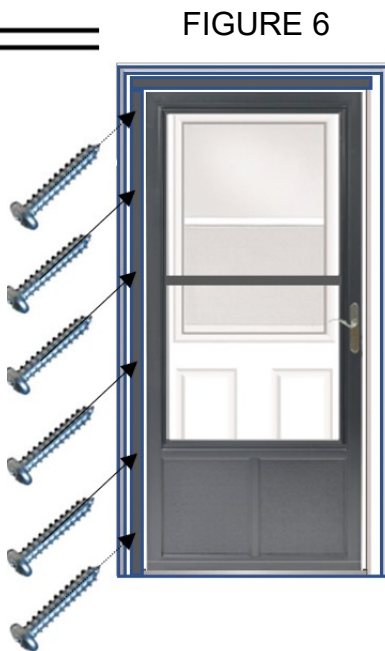

FIGURE 6

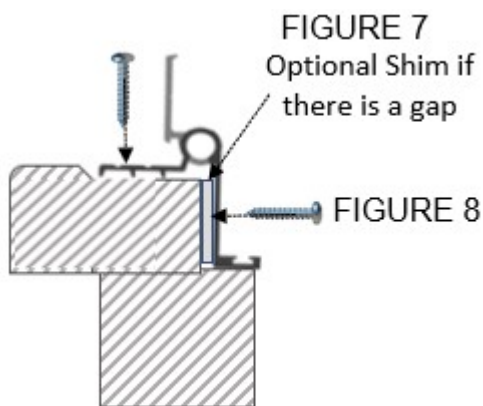

FIGURE 7

Optional Shim if there is a gap

FIGURE 8



6. Install two 1/2" self tapping () screws in each of the four hinges.
7. With the latch rail attached to the door, you are now ready to install the door into the opening.
8. **INSTALLING DRIP CAP:** See (Figure 4). To install the drip cap, center it on the brickmold from side to side. Verify the brickmold is level before attaching the drip cap. Then install two #10 1 1/4" screws in each end. (). After attaching the drip cap, check that it is level as well. **NOTE:** If you want to reduce the potential of the wood splitting when you install the screws, then predrill a pilot hole with a drill bit smaller than the screw. This would typically be no larger than a 3/32" drill bit size. Do not predrill your hole more than 1/3 the length of the screw into the wood.
9. **INSTALLING DOOR IN OPENING:** Place the door with the hinge rail attached into the door opening. Line the top of the hinge rail with the edge of the drip cap. You should see a 1/16" to 1/8" gap / reveal (Figure 5) between the top of the door and the bottom of the drip cap if the hinge rail is attached properly to the door. Once you verify this gap and ensure the hinge rail lines up with the edge of the drip cap, install one #10 1 1/4" screw through the top hole of the hinge rail above the top hinge of the door (Figure 6). Next you want to check the door with a level to ensure the door is hanging straight. Additionally check that the gap between the door and the drip cap is consistent all the way across the top. Once you are sure the door is where you want it, install another #10 1 1/4" screw through the bottom hole of the hinge rail. **NOTE:** If you find that there is a gap between the brickmold and the hinge rail, it is wise to fill this space with a wood shim to give the leg of the hinge rail something to sit against. See (Figure 7). Check the squareness of the door with a level one more time and ensure you like the way it swings when you open it. Once you are satisfied, install the other four #10 1 1/4" screws in the face of the latch rail, then open the door and install four more in the holes above each hinge (FIGURE 8). **NOTE: DO NOT OVER TIGHTEN THE SCREWS.** It could damage the paint on the hinge rail.

FIGURE 9

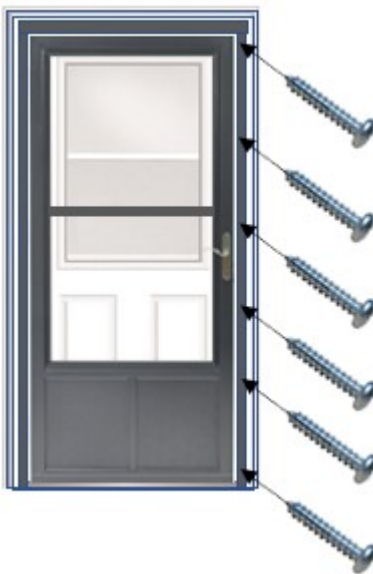
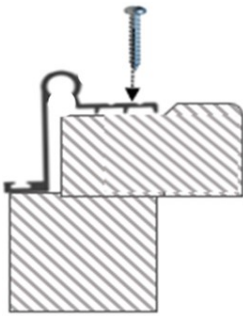
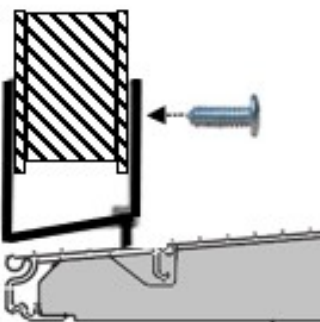



FIGURE 10



10. **CUTTING THE LATCH RAIL:** Using a tape measure check the length of the latch side by measuring from the top of the door sill to the bottom of the drip cap. Similar to (Figure 2). It should be very close to the length of the hinge rail. After double checking this length use your tape measure and pencil to mark where you are going to cut the hinge rail. Using a fine tooth hack saw make your cut on the hinge rail / (threshold). For a nicer look make your cut the same angle as the slope of the door sill / (threshold).

11. **INSTALLING THE LATCH RAIL:** Open the door slightly so that you can place your latch rail over the brickmold and between the edge of the door. Line up the latch rail with the edge of the drip cap and ensure it is tight up against the drip rail. At this point you should have about a 1/8" gap between the edge of the door and the latch rail. Install one #10 1 1/4" screw in the top hole of the latch rail. With the door closed line up your latch rail so that you have a consistent even gap all the way down between the door and the latch rail. Install one more #10 1 1/4" screw in the bottom hole. **NOTE:** If you find that there is a gap between the brickmold and the latch rail, it is wise to fill this space with a wood shim to give the leg of the latch rail something to sit against as discussed in step 9. After verifying that the door does not rub the latch rail when opening and closing, and that you have a consistent 1/8" gap all the way down the reveal, continue to install the other four #10 1 1/4" screws in the latch rail as seen in (Figure 9). It is optional, but if you want to run a clear bead of caulk around the entire perimeter where the rails and drip cap meet the entry door brickmold, this will reduce any potential water infiltration.

12. **INSTALLING THE EXPANDER:** At this point the door should be swinging easily and there should be no rubbing between the drip cap, the latch rail, and the door. If no more adjustment is needed, then it is time to install the expander. See (Figure 10). Open the door and slide the expander over the bottom of the door. The weather strip should be toward the inside. With the door shut you want no more than a 1/4" gap between the threshold and the front bottom of the expander and the weatherstrip to just touch the door sill. On the inside of the door predrill two holes with a 3/32" drill bit and install the two #8 3/8" screws ().

INSTALLATION

STEP 1

While keeping the sides compressed, place one top corner of the screen into the screen track.



STEP 2

Keeping both sides compressed, place the opposite top corner into the screen track.



STEP 3

Continue to keep sides compressed, and insert screen into a bottom corner. [Lift slightly if your window has a lip on the sill.] Release this side of the screen.



STEP 4

Place the last corner into the screen track and release completely once all corners are in place.



REMOVAL

STEP 1

Gently press on the center of the screen until you can wrap your hands around the FlexScreen frame. Squeeze both sides inward 4"-6".



STEP 2

While keeping the sides compressed, lift the screen up and remove one of the bottom corners from the screen track.



STEP 3

Remove the opposite bottom corner from the screen track.



STEP 4

With both corners out of the screen track, pull FlexScreen down from the top and remove the screen.



- 13. INSTALLING LOCK HARDWARE:** Depending on which lock option was chosen, it is important to follow the instructions included with your lock when installing the hardware. In most cases a door lock template will come in the lock box that helps you drill your holes in the correct locations. Please do not use a power screw driver while tightening the screws for the handle or the dead-bolt. Doing so may cause the screws to strip and be unusable. Also, do not overtighten the hardware, or it can cause the lock to bind.



14. REINSTALLING GLASS AND SCREEN (SELF STORE):

If your unit is a self storing, then there will be one FLEX screen and two glass panels. To better shed water the outer glass panel should be in the up position, and the inner glass panel in the lower position. You can adjust either panel in different locations when venting, but to reduce water from coming in through the glass panels, make sure you have the outer panel in the up position. The FLEX Screen allows for screen removal in seconds and provides full vertical movement of both the upper and lower. See left side of page for instructions on the FLEX Screen.

15. REINSTALLING GLASS AND SCREEN (NON-SELF STORE):

The non-self store option allows you to completely switch out your glass with a screen or the screen with the glass. You can not store both in the door frame at the same time. To remove the panel you will need to loosen the thumb screw on each wing clip. When they are all loose, you can turn the wing clips 90 degrees so that you can pull out the glass or screen panel. To install the panel just turn the wing clip so that the foot of the clip is on the panel and then tighten the thumb screw (by hand). Ensure all wing clips are properly located and the thumb screws are hand tight.

- 16. CLOSER INSTALLATION:** Ensure that the door opens and closes smoothly with no binding before you install your closer. It is important to read through the installation instructions completely to ensure proper operation of the door.

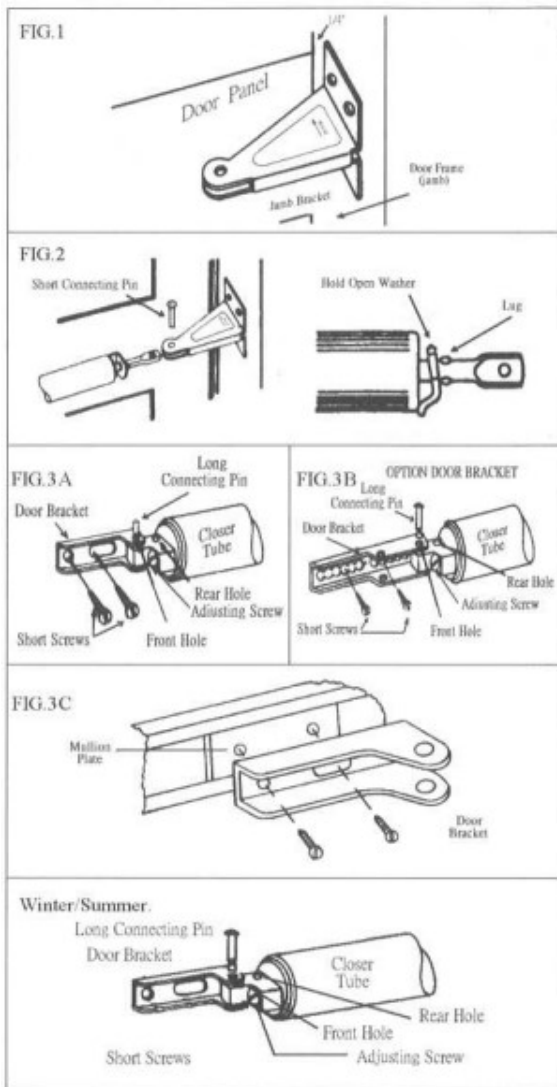

17. CLOSER INSTALL (FIGURE 1): The closure may be installed on a rail at the top, center, or bottom of the door. Use a 1/8" drill bit for all pilot holes. Prior to installing screws into any part of the entry door jamb, make sure to always drill pilot holes to prevent the entry door jamb from splitting. At the desired height, fasten the jamb bracket to the entry door frame with open the side 1/4" from the storm door. **Note:** Moving jamb bracket up to 1" away from door increases latching force but will normally reduce door swing opening.

18. CLOSER INSTALL (FIGURE 2): Slide the hold open washer on to the rod, with short connecting pin connect closer to jamb bracket. Pull closer out slightly to position hold open washer over lugs and against tube. **Do not change until installation is complete.**

19. CLOSER INSTALL (FIGURE 3): With door tightly closed, attach door bracket to front hole in closer with the short connecting pin. Making sure closer is level, hold closer and door bracket against door. Mark and drill two 1/8" holes. **Caution: Do not drill through outside face of the door.** Fasten door bracket to door using two short screws. Open door and move the hold open washer back behind the lug on the rod. Closer speed may be adjusted by turning adjusting screw on end of closer.

20. SAFETY CHAIN INSTALL (FIGURE 1): Wind chain must be installed in all cases. **Note:** To prevent over extension of the closure, the wind chain must be set so that it stops the door before the closer reaches its full extension. Attach the bracket on spring end to the entry door head jamb 18" from the hinge side of the door.

21. SAFETY CHAIN INSTALL (FIGURE 2): Mount 2nd bracket on top of door 19" from hinge side of door in horizontal position. This allows for a 90 degree opening of door, if more than a 90 degree opening is desired move both brackets closer to hinge side of door.

22. SAFETY CHAIN INSTALL (FIGURE 3): Close door and attach hold up spring, by twisting hold up spring to the lowest link of the chain. If the chain has vinyl sleeve at lowest point then pierce the vinyl sleeve and attach the hold up spring.

24. SAFETY CHAIN INSTALL (FIGURE 4): Swing chain toward hinge side of door and fasten hold up spring to head jamb with a nail, about 3" from door jamb.

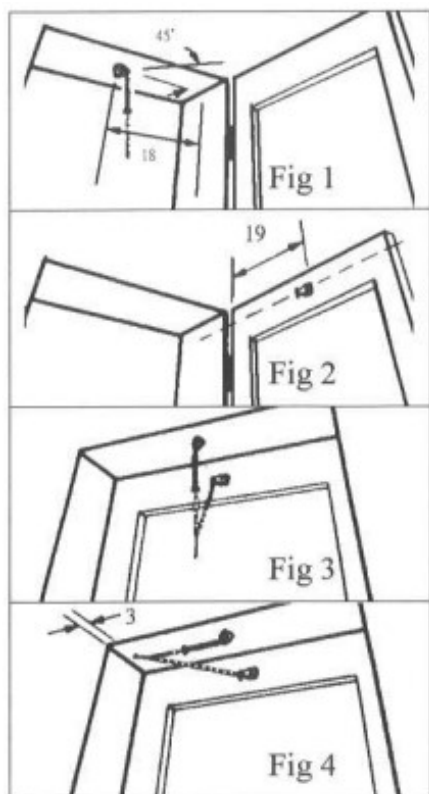

General Care and Maintenance

Glass: With a soft cloth or paper towel use warm water mixed with a mild detergent or a general household glass cleaner to clean your glass.

Door Finish: Use a mild soap and water mixture to clean the door. Additionally you can use a non-abrasive wax or Armor All to bring back the shine to the powder coat. If you live near a coastal region it is important to clean your door more often.

Closer: It is possible that your screen/storm door closer may need adjusted when you switch from a screen to the glass panel. To do this you will need to adjust the tension on the closer. Locate the tension adjustment screw on the end of the door closer. Turn the screw clockwise to tighten and make the door close slower. Turn the screw counter-clockwise to loosen and make the door close faster.

Door Lock: A periodic cleaning with a mild soap and water solution is recommended. Care and maintenance of your hardware is especially important if you live in or near a coastal or industrial environment to prevent hardware corrosion which may result from the presence of airborne chemicals.

Trouble Shooting

ISSUE	POTENTIAL CAUSE	SOLUTION
Door not closing all the way or closing slowly.	Closer speed not set correctly.	See instruction manual for the installation and adjusting the closer. You likely need to adjust the adjustment screw.
	Closer not installed correctly.	Verify the jamb bracket is the correct distance from the door.
		Verify the door bracket is in the correct location on the storm door.
		Recheck closer installation to the closer installation instructions.
	Hinge is binding on the hinge rail. Because the hinge rail is twisted.	Slightly loosen any screws on the hinge rail that may be causing the hinge rail to twist. Do this until hinge rail is straight and square.
	Bottom expander is dragging.	Slightly raise the bottom expander until the sweep barely touches the entry door threshold.
	Air pressure between the storm door and entry door.	Slightly raise the bottom expander in order to allow air to escape.
		If a self storing unit then you can open the lower glass panel to allow a place for the air to escape.
	Door is out of square	Recheck your installation. Verify a good reveal of at least 1/16" but no more than 1/8" between door drip cap and door latch rail.
Edge of expander is hitting the hinge or latch rails.	Ensure the expander is flush on each end of the door and not hanging over.	
Closer rod is bent.	If closer rod got bent because door was over extended then you will need to replace the closure.	

Aluminum Storm Door Lifetime Limited Warranty

The manufacturer warrants to you, the original purchaser of the **Aluminum Storm Door**, that the product will be free from defects in material and workmanship.

DOOR FRAME & HINGES

The manufacturer warrants the door frame, hinges and painted finish* to be free from defects in materials and workmanship under normal use for as long as you, the original purchaser owns and resides in the home in which the product was installed. **Luma Stain Doors - see below

COMPONENTS

Components of the door are warranted for one year from the original date of purchase. These components include retainer clips, door closure, screen frame, and glass frame. Components are warranted to be free from defects in material and workmanship.

LOCKS

The lockset is warranted for a period of one year from the date of original purchase. The warranty covers both the mechanical operation and the finish for the one year period.

WARRANTY LIMITATIONS AND EXCLUSIONS

*Fading of the paint finish is a natural occurring process and is excluded from this warranty. Glass breakage or screen mesh tears / holes are excluded from this warranty. Modifications of the product in any form will void this warranty. This warranty only applies to the original purchaser of the product in the original owner occupied residential property. Acts of nature such as flooding, wind damage, earthquakes or any other acts of nature are not covered under this warranty. Any damages resulting from misuse of the product or from improper installation are not covered under this warranty. The manufacturer is not liable for any additional costs incurred such as labor or re-installation fees. Water damage due to a lack of rain diversion or structural overhang is not covered under warranty. Your exclusive remedy is limited to the replacement of the defective part or parts.

**Luma Stain Doors - stain finish warranted for 3 years. Does not include chips or scratches that may occur due to everyday usage